

Notice

Hewlett-Packard to Agilent Technologies Transition

This documentation supports a product that previously shipped under the Hewlett-Packard company brand name. The brand name has now been changed to Agilent Technologies. The two products are functionally identical, only our name has changed. The document still includes references to Hewlett-Packard products, some of which have been transitioned to Agilent Technologies.



Agilent Technologies

HP 11757B
Multipath Fading Simulator

Installation and Calibration Guide



HP Part No. 11757-90058
Printed in UK
October 1998

© Copyright Hewlett-Packard Ltd. 1998

Notice

The information contained in this document is subject to change without notice.

Hewlett-Packard shall not be liable for errors contained herein or for incidental or consequential damages in connection with the furnishing, performance, or use of this material.

This document contains proprietary information which is protected by copyright. All rights are reserved. No part of this document may be photocopied or reproduced without the prior written consent of the manufacture, Hewlett-Packard Ltd.

© Copyright Hewlett-Packard Ltd. 1998.

All Rights Reserved. Reproduction, adaptation, or translation without prior written permission is prohibited, except as allowed under the copyright laws. Station Road, South Queensferry, Scotland, EH30 9TG, UK.

By internet, phone, or fax, get assistance with all your test and measurement needs.

Table 1-1 Contacting Agilent

Online assistance: www.agilent.com/find/assist

United States
(tel) 1 800 452 4844

Latin America
(tel) (305) 269 7500
(fax) (305) 269 7599

Canada
(tel) 1 877 894 4414
(fax) (905) 282-6495

Europe
(tel) (+31) 20 547 2323
(fax) (+31) 20 547 2390

New Zealand
(tel) 0 800 738 378
(fax) (+64) 4 495 8950

Japan
(tel) (+81) 426 56 7832
(fax) (+81) 426 56 7840

Australia
(tel) 1 800 629 485
(fax) (+61) 3 9210 5947

Asia Call Center Numbers

Country	Phone Number	Fax Number
Singapore	1-800-375-8100	(65) 836-0252
Malaysia	1-800-828-848	1-800-801664
Philippines	(632) 8426802 1-800-16510170 (PLDT Subscriber Only)	(632) 8426809 1-800-16510288 (PLDT Subscriber Only)
Thailand	(088) 226-008 (outside Bangkok) (662) 661-3999 (within Bangkok)	(66) 1-661-3714
Hong Kong	800-930-871	(852) 2506 9233
Taiwan	0800-047-866	(886) 2 25456723
People's Republic of China	800-810-0189 (preferred) 10800-650-0021	10800-650-0121
India	1-600-11-2929	000-800-650-1101

Declaration of Conformity

Declaration of Conformity

according to ISO/IEC Guide 22 and EN45014

Manufacturer's Name: Hewlett-Packard Ltd.

Manufacturer's Address:
Queensferry Microwave Division
South Queensferry
West Lothian, EH30 9TG
Scotland, United Kingdom

Declares that the product

Product Name: Multipath Fading Simulator

Model Number: HP 11757B

Product Options: This declaration covers all options of the above product as detailed in TCF A-5951-9852-02

Conforms with the protection requirements of European Council Directive 89/336/EEC on the approximation of the laws of the member states relating to electromagnetic compatibility, against EMC test specifications EN 55011:1991 (Group 1, Class A) and EN 50082-1:1992 .

As Detailed in: Electromagnetic Compatibility (EMC)
Technical Construction File (TCF) No. A-5951-9852-02

Assessed by: DTI Appointed Competent Body
EMC Test Centre,
GEC-Marconi Avionics Ltd.,
Maxwell Building,
Donibristle Industrial Park,
KY11 5LB
Scotland, United Kingdom

Technical Report Number:6893/2201/CBR, dated 23 September 1997

Supplementary Information:

The product conforms to the following safety standards:

EN 61010-1(1993) / IEC 1010-1(1990) +A1(1992) +A2(1995)
CSA-C22.2 No. 1010.1-93
EN 60825-1(1994) / IEC 825-1(1993)

The product herewith complies with the requirements of the Low Voltage Directive 73/23/EEC, and carries the CE marking accordingly.

South Queensferry, Scotland

01 October 1998



Location

Date

R.M. Evans / Quality Manager

Europe Contact:

Your Local Hewlett-Packard Sales and Service Office or Hewlett-Packard GmbH, Department 2Q / Standards
Europe Herrenberger Strasse 130, D7030 Boblinger (Fax: +49-7031-143143)

General Safety Information

The following general safety precautions must be observed during all phases of operation, service, and repair of this instrument. Failure to comply with these precautions or with specific warnings elsewhere in this manual violates safety standards of design, manufacture, and intended use of the instrument. Hewlett-Packard Company assumes no liability for the customer's failure to comply with these requirements.

WARNING



This is a Safety Class I instrument (provided with a protective earthing ground, incorporated in the powercord). The mains plug shall only be inserted in a socket outlet provided with a protective earth contact. Any interruption of the protective conductor inside or outside of the instrument is likely to make the instrument dangerous. Intentional interruption is prohibited.

DO NOT operate the product in an explosive atmosphere or in the presence of flammable gasses or fumes.

DO NOT use repaired fuses or short-circuited fuseholders: For continued protection against fire, replace the line fuse(s) only with fuse(s) of the same voltage and current rating and type.

DO NOT perform procedures involving cover or shield removal unless you are qualified to do so: Operating personnel must not remove equipment covers or shields. Procedures involving the removal of covers and shields are for use by service-trained personnel only.













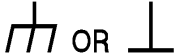

DO NOT service or adjust alone: Under certain conditions, dangerous voltages may exist even with the equipment switched off. To avoid dangerous electrical shock, service personnel must not attempt internal service or adjustment unless another person, capable of rendering first aid and resuscitation, is present.

DO NOT operate damaged equipment: Whenever it is possible that the safety protection features built into this product have been impaired, either through physical damage, excessive moisture, or any other reason, **REMOVE POWER** and do not use the product until safe operation can be verified by service-trained personnel. If necessary, return the product to a Hewlett-Packard Sales and Service Office for service and repair to ensure the safety features are maintained.

DO NOT substitute parts or modify equipment: Because of the danger of introducing additional hazards, do not install substitute parts or perform any unauthorized modification to the product. Return the product to a Hewlett-Packard Sales and Service Office for service and repair to ensure the safety features are maintained.

Safety Symbols

The following symbols on the instrument and in the manual indicate precautions which must be taken to maintain safe operation of the instrument.

	The Instruction Documentation Symbol. The product is marked with this symbol when it is necessary for the user to refer to the instructions in the supplied documentation.
	Indicates the field wiring terminal that must be connected to earth ground before operating the equipment - protects against electrical shock in case of fault.
	Frame or chassis ground terminal - typically connects to the equipment's metal frame.
	Alternating current (AC)
	Direct current (DC)
	Indicates hazardous voltages
WARNING 	Warning denotes a hazard. It calls attention to a procedure, which if not correctly performed or adhered to could result in injury or loss of life. Do not proceed beyond a warning note until the indicated conditions are fully understood and met.
CAUTION 	Caution denotes a hazard. It calls attention to a procedure, which if not correctly performed or adhered to could result in damage to or destruction of the instrument. Do not proceed beyond a caution note until the indicated conditions are fully understood and met.
	The CE mark shows that the product complies with all relevant European Legal Directives.
ISM 1-A	This is a symbol of an Industrial, Scientific, and Medical Group 1 Class A product.
	The CSA mark is a registered trademark of the Canadian Standards Association, and indicates compliance to the standards laid out by them.
	The C-Tick mark is a registered trademark of the Spectrum Management Agency of Australia. This signifies compliance with the Australian EMC Framework Regulations under the terms of the Radiocommunications Act of 1992.
	This symbol indicates the position of the operating switch for 'Off' mode. NOTE: To ensure instrument is isolated from mains, always remove the appliance coupler (mains power cord) from the power source.
	This symbol indicates the position of the operating switch for 'On' mode.
	This symbol indicates the position of the operating switch for 'Stand-by' mode. Note, the instrument is NOT isolated from the mains when the switch is in this position. To isolate the instrument, the mains coupler (mains input cord) should be removed from the power supply.

Safety Considerations

This product and related documentation must be reviewed for familiarization with safety markings and instructions before operation.

This product is a Safety Class I system (provided with a protective earth terminal).

Before Applying Power

Verify that the product is set to match the available line voltage and the correct fuses are installed.

Safety Earth Ground

An uninterruptible safety earth ground must be provided from the main power source to the product input wiring terminals, power cable, or supplied cable set.

WARNING:



Any interruption of the protective (grounding) conductor (inside or outside the system) or disconnecting the protective earth terminal will cause a potential shock hazard that could result in personal injury. (Grounding one conductor of a two conductor outlet is not sufficient protection.) In addition, verify that a common ground exists between the unit under test and the system prior to energizing either unit.

Service instructions are for use by service-trained personnel only. To avoid dangerous electric shock, do not perform any servicing unless qualified to do so.

Adjustments described in the manual are performed with the power supplied to the system's instruments while protective covers are removed. Energy available at many points may, if contacted, result in personal injury.

Installation and Calibration

Introduction

This section provides the information needed to install the HP 11757B Multipath Fading Simulator. Included is information pertinent to initial inspection, power requirements, line voltage selection, power cables, interconnection, environment, instrument mounting, storage, and shipment. In addition, this section contains the procedures for selecting the impedance of the instrument inputs and setting the HP-IB address.

Initial Inspection

Warning



To avoid hazardous electrical shock, do not turn on the instrument when there are signs of shipping damage to any portion of the outer enclosure (covers, panels, display).

Inspect the shipping container for damage. If the shipping container or cushioning material is damaged, it should be kept until the contents of the shipment have been checked for completeness and the instrument has been checked mechanically and electrically. Procedures for checking electrical performance are given in the service manual as well as in the automated performance tests found in this manual. If the contents are incomplete, if there is mechanical damage or defect, or if the instrument does not pass the electrical performance

tests, notify the nearest Hewlett-Packard office. If the shipping container is damaged, or the cushioning material shows signs of unusual stress, notify the carrier as well as the Hewlett-Packard office. Keep the shipping materials for the carrier's inspection.

Preparation for Use

Warning



To avoid damage to the instrument make sure that the voltage selection switch on the back of the instrument is set properly.

This is a Safety Class I product (that is, it is provided with a protective earth terminal). An uninterruptible safety earth ground must be provided from the main power source to the product input wiring terminals through the power cable or supplied power cable set. Whenever it is likely that the protection has been impaired, the product must be made inoperative and be secured against any unintended operation.

If this instrument is to be energized via an external autotransformer, make sure the autotransformer's common terminal is connected to neutral (that is, the grounded side of the line (Mains) supply.)

Installation Checklist

Before plugging the Fader into the line (Mains) voltage, ensure the following steps are taken:

1. Check the line (Mains) voltage to ensure compatibility with the Fader requirements.
2. Check the line voltage switch on the Fader's rear panel to ensure proper selection for the line (Mains) voltage.

3. Ensure that the power cable to be used is the required type.

Caution



BEFORE PLUGGING THIS INSTRUMENT into the line (Mains) voltage, make sure that the correct voltage and fuse have been selected.

4. Plug in the power cable.

Cooling



To provide adequate cooling, an air gap of approximately 75mm should be maintained around the instrument.

Power Requirements

The Fader requires a power source of 115 or 230 $\pm 10\%$ Vac, 50 to 60 Hz.
Power consumption is <200 VA.

Line Voltage Selection

Caution



BEFORE PLUGGING THIS INSTRUMENT into the line (Mains) voltage, make sure that the correct operating voltage and fuse has been selected.

1. On the rear panel of the Fader is a red recessed switch for selecting the operating voltage. It is labeled **Voltage Selector**. Check the switch setting to see if it reads 115V or 230V (only the voltage selected is visible).
2. If the voltage switch is set improperly, use a fingernail or a small flathead screwdriver to switch it to the correct setting.

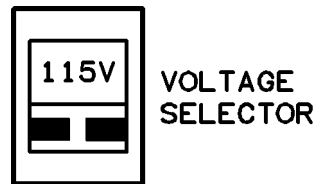

Figure 1-1. Voltage Selection

Fuse Replacement

To check or replace the fuse:

1. Remove the power cable from the back panel of the Fader.
2. The plastic receptacle into which the power cable is plugged contains a small drawer containing the fuse. This drawer cannot be opened when the power cord is connected to the back panel of the Fader. Beneath the center prong (ground) is a tab. At the bottom of the plastic receptacle is another tab.
3. With your fingers or a small flathead screwdriver pull back on the tabs. The drawer will open.

Note



The fuse is disconnected from the circuit when the drawer is opened. You can check the fuse with a continuity light to see if it has opened without removing the fuse from the drawer.

4. Using a screwdriver push either end of the fuse down from above until the other end pops up.
5. Remove the fuse from above with your fingers or needlenose pliers.
6. Place the new fuse into the slot and close the fuse drawer.

Note

The fuse should be an IEC approved 5 by 20 mm ceramic case, sand filled 5 Amp 250V Fast Blow. If your instrument is new, there will be a spare fuse in the fuse drawer. The fuse drawer has a slot for storing an extra fuse.

7. Reconnect the power cord.

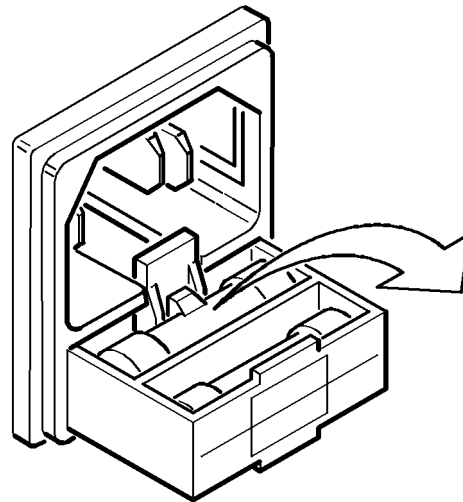

Figure 1-2. Fuse assembly

Power Cables**Warning**

BEFORE CONNECTING THIS INSTRUMENT, the protective earth terminals of this instrument must be connected to the protective conductor of the line (Mains) power cable. The line plug shall only be inserted in a socket outlet provided with a protective earth contact. The protective action must not be negated by the use of an extension cord (power cable) without a protective conductor (grounding). Grounding one conductor of a two conductor outlet is not sufficient protection.

Installation and Calibration

HP 11757B

This instrument is equipped with a three-wire power cable. When connected to an appropriate AC power receptacle, this cable grounds the instrument chassis. The type of power cable plug shipped with each instrument depends on the country of destination. See figure 1-3, "Power Cable and Line (Mains) Plug Part Numbers", for the part numbers of these power cables. Cables are available in different lengths and some with right angle plugs to the instrument. Check with your nearest Hewlett-Packard service center for descriptions and part numbers for these cables.

<p>HP 8120-1351 BS 1363A PLUG</p>  <p>UNITED KINGDOM</p>	<p>HP 8120-1369 NZSS 198/AS 3112 PLUG</p>  <p>AUSTRALIA/NEW ZEALAND</p>	<p>HP 8120-1689 CEE 7 STD SHT VII, DIN 49441, VDE 0620</p>  <p>CONTINENTAL EUROPE</p>
<p>HP 8120-1378 NEMA 5-15P</p>  <p>U. S. /CANADA (NOT INTERCHANGEABLE WITH 8120-4753)</p>	<p>HP 8120-1575 IEC 320-C14</p>  <p>SWITZERLAND</p>	<p>HP 8120-2104 SEV 1011.1959-24507 TYPE 12 PLUG</p>  <p>SWITZERLAND</p>
<p>HP 8120-2956 DHCR 107 PLUG</p>  <p>DENMARK</p>	<p>HP 8120-4211 IEC 83, STD 81 (SABS 164)</p>  <p>REPUBLIC OF SOUTH AFRICA and INDIA</p>	<p>HP 8120-4753 MITI 41-9892 PLUG</p>  <p>JAPAN (NOT INTERCHANGEABLE WITH 8120-1378)</p>

Figure 1-3. Power Cable and Line (Mains) Plug Part Numbers

HP-IB Address Selection and Configuring

HP-IB Address Selection

The HP-IB address is selectable from the front panel.

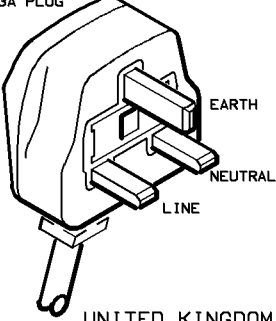
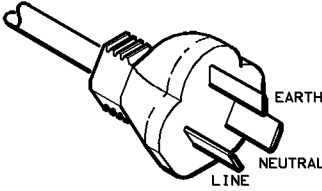
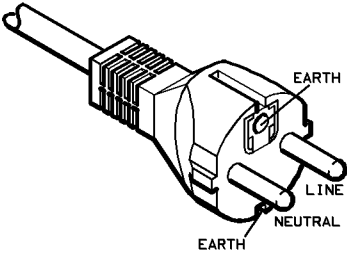
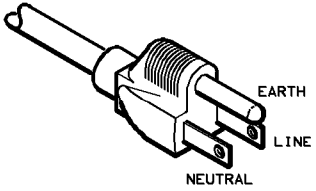
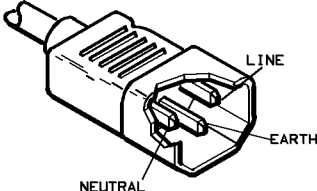
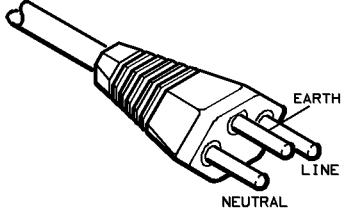
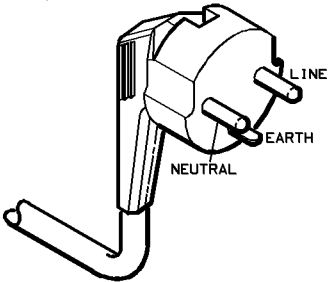
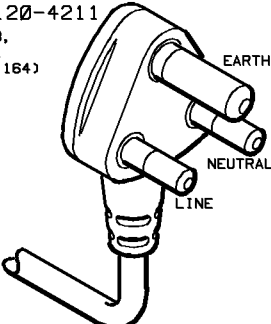
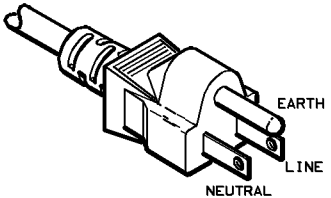
When shipped from the factory the address of the instrument is 14. HP-IB addresses from 00 to 30 as well as 40 (listen only) and 50 (talk only) can be used. A list of allowable addresses is given in table 1-1.

Use the following procedure to set the HP-IB address:

1. Press **SHIFT** **PRESET/LOCAL** (the MORE function).
2. Press **▲** or **▼** until the display reads “5 HP-IB ADRS”.
3. Press the **ENTER** key. The display will read “ADDRESS 14”.
4. Press **▲**, **▼**, **◀** or **▶** until the desired HP-IB address is displayed.
5. Press the **ENTER** key.

Table 1-1.
Allowable HP-IB Address Codes

Talk Address Character	Listen Address Character	Decimal Equivalent
@	SP	0
A	!	1
B	"	2
C	#	3
D	\$	4
E	%	5
F	&	6
G	'	7
H	(8
I)	9
J	*	10
K	+	11
L	,	12
M	-	13
N	.	14 ¹
O	/	15
P	0	16
Q	1	17
R	2	18
S	3	19
T	4	20
U	5	21
V	6	22
W	7	23
X	8	24
Y	9	25
Z	:	26
[;	27
}	<	28
]	=	29
^	>	30

¹Factory-set Fading Simulator address.

Interconnections

Interconnection data for the Hewlett-Packard Interface Bus is provided in figure 1-4, Hewlett-Packard Interface Bus Connection.

HP-IB Interface Connector

The HP-IB mating connector is shown in figure 1-4, Hewlett-Packard Interface Bus Connection. Note that the two securing screws are metric.

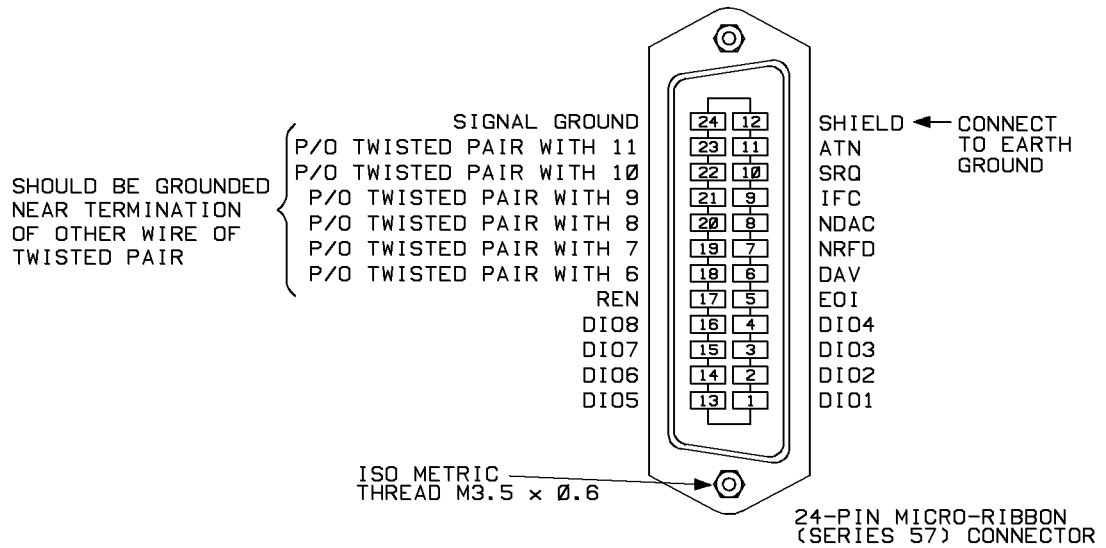

Logic Levels

The Hewlett-Packard Interface Bus Logic Levels are TTL compatible, i.e., the true (1) state is 0.0 Vdc to +0.4 Vdc and the false (0) state is +2.5 Vdc to +5.0 Vdc.

Mating Connector

HP 1251-0293; Amphenol 57-30240.

Mating Cables Available

HP 10833A, 1 metre (3.3 ft), HP 10833B, 2 metres (6.6 ft)
 HP 10833C, 4 metres (13.2 ft), HP 10833D, 0.5 metre (1.6 ft)

Cabling Restrictions

1. A Hewlett-Packard Interface Bus system may contain no more than 2 metres (6.6 ft) of connecting cable per instrument.
2. The maximum accumulative length of connecting cable for any Hewlett-Packard Interface Bus system is 20.0 metres (65.6 ft).

Figure 1-4. Hewlett-Packard Interface Bus Connection

Coaxial Connectors

The IF INPUT and the IF OUTPUT on the front panel, and the AUX IF OUT on the rear panel require 75Ω BNC male mating connectors compatible with the specifications of US MIL-C-39012.

IF Input Signal

The best Fader performance is found at IF INPUT levels of -8 dBm. Performance is very good to -3 dBm. If you have a more powerful signal use an attenuator before inputting it to the IF Input of the Fader. If you have a signal that is much weaker than -8 dBm, consider using an amplifier.

Caution



Do not input power exceeding +20 dBm to the IF Input of the Fader. This could damage the instrument.

Error Pulse Input

The error pulse input is internally configurable to the following:

- ECL 75Ω (default)
- TTL 75Ω
- TTL 10kΩ
- Variable threshold, -2 volt termination, 75Ω
- Variable threshold, 0 volt termination, 75Ω
- Variable threshold, 0 volt termination, 10kΩ

To make the appropriate setting press the **RADIO SETUP** key, and then press **▲** until **1 ERROR TERM** is displayed. Press **ENTER** and use **▲** to toggle through the options listed above. Press **ENTER** again when you have the correct input for your radio.

After selecting one of the options listed above and pressing **ENTER**, the selection **1.1 ERROR THR** is displayed. Press **ENTER** and change the trigger

threshold if desired. Press **ENTER** again when you have the correct input threshold for your radio. Error pulse input variable threshold is only available in serial prefixes 3235A and above.

Alarm Input

The alarm input (TTL 10k Ω) may be set for polarity. The default setting is positive. To change the polarity press **RADIO SETUP**, and then press **▲** until **2 ALARM POL** is displayed. Press **ENTER**, and then use **▲** to toggle between positive and negative. Press **ENTER** when you have the polarity you want.

Printer

The Fader's internal printer uses thermal paper, HP part number 9270-1299. To load a new roll of paper into the Fader:

Caution



Never pull the paper from the Fader. Use the **PAPER FEED** key. Failure to do so could cause permanent damage to the print head.

1. The Fader must be plugged in and the power switch set to on.
2. Turn the knob on the paper holder counter-clockwise several times until the paper holder can be pulled out of the Fader.
3. Slide the paper cover off the paper holder.
4. Using a posidrive or a phillips screwdriver remove the screw from the top of the paper roll (screw counter-clockwise). Remove the plastic washer and the old roll of paper.
5. Place a new roll of paper on the paper post so that paper will roll off the post in a clockwise direction.
6. Place the plastic washer on top of the roll and replace the screw (screw counter-clockwise).

7. Place the paper cover back on and pull some paper out on the side of the cover closest to the paper feeder.

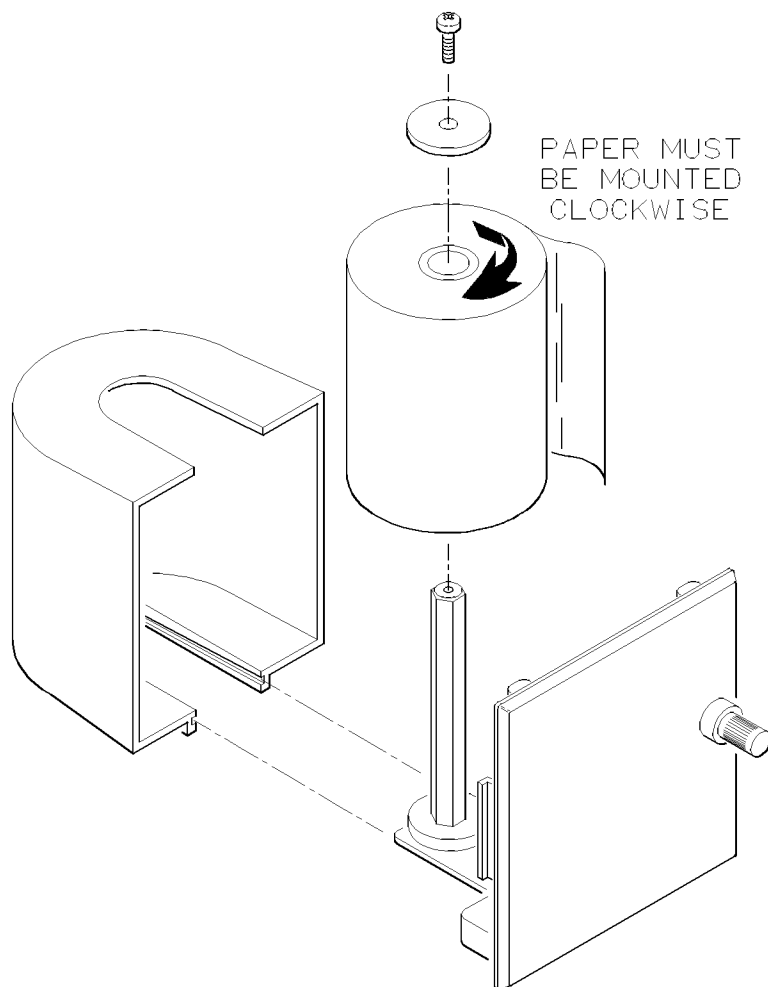

Figure 1-5. Paper Holder

8. Cut the end of the paper square.

9. Feed the end of the paper into paper slot while pressing **PAPER FEED** repeatedly. Keep pressing **PAPER FEED** until paper scrolls through the paper tear at the front of the Fader.

Note



The paper slot may be hard for some users to see. It consists of a black plastic feed and a metal backing. The paper must be placed between these parts, and as parallel to the base of the instrument as possible. If you experience difficulty, try examining the feed and backing with a flashlight first.

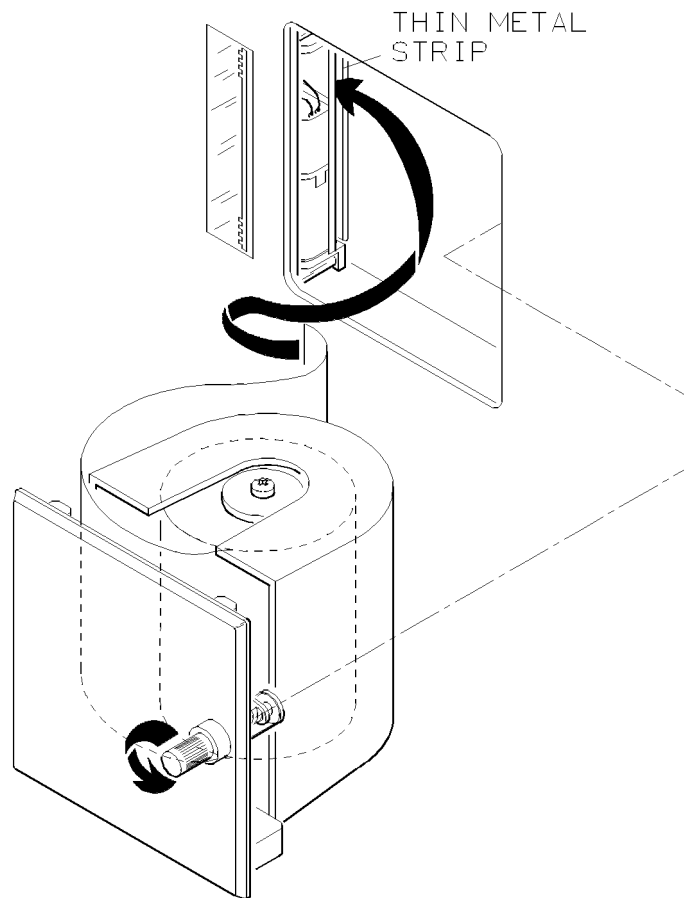

Figure 1-6. Paper Feed

10. Place the paper holder back into the Fader and turn the knob clockwise until the holder is firmly in place.
11. Press **PAPER FEED** to see if the feeder is still operating. If it is not, start the loading process over.

Operating Environment

The operating environment is specified to be within the following limitations:

Temperature0°C to +55°C
 Humidity <95% relative
 Altitude <4570 metres (15 000 feet)

Rack Mounting

The Fader may be rack mounted using Hewlett-Packard sub-module cabinets. The HP part numbers for the rack mounting kits are as follows:

- Without Handles: 5062-4840
- With Handles: 5062-4841

Storage and Shipment

Environment

The instrument should be stored in a clean, dry environment. The following environmental limitations apply to both storage and shipment:

Temperature -55°C to +75°C
 Humidity <95% relative
 Altitude <15 300 metres (50 000 feet)

Packaging

Tagging for Service

If the instrument is being returned to Hewlett-Packard for service, please complete one of the blue repair tags located at the end of this manual and attach it to the instrument.

To minimize repair time, be as specific as possible when describing the failure. Keep the following two items in mind when describing the failure:

1. Describe what makes you think the instrument is failing. An example might be “Flat fade attenuation does not work.”
2. If the failure only occurs under certain conditions, explain how to duplicate the failure. An example might be “Flat fade attenuation will not operate at 22.0 dB.”

Original Packaging

Containers and materials identical to those used in factory packaging are available through Hewlett-Packard offices. Mark the container “FRAGILE” to encourage careful handling. In any correspondence, refer to the instrument by model number and full serial number.

Other Packaging

The following general instructions should be used for repackaging with commercially available materials.

1. Wrap the instrument in heavy paper or plastic. If shipping to a Hewlett-Packard office or service center, complete one of the blue tags mentioned above and attach it to the instrument.
2. Use a strong shipping container. A double-wall carton made of 2.4 MPa (350 psi) test material is adequate.
3. Use enough shock-absorbing material (75 to 100 mm layer; 3 to 4 inches) around all sides of the instrument to provide a firm cushion and prevent movement in the container. Protect the front panel with an appropriate type of cushioning material to prevent damage during shipment.
4. Seal the shipping container securely.

5. Mark the shipping container "FRAGILE" to encourage careful handling.

General Operating Instructions

Warning



Before the Fader is switched on, all protective earth terminals, extension cords, autotransformers, and devices connected to the instrument should be connected to a protective earth grounded socket. Any interruption of the protective earth grounding will cause a potential shock hazard that could result in personal injury.

Caution



Before the Fader is switched on, it must be set to the same line voltage as the power source or damage to the instrument may result. Refer to the Installation Guide for instructions.

Turn-On Procedure

If the power cable is not plugged in, follow these instructions.

On the rear panel:

1. Check the line voltage selection switch for correct voltage selection. Set to 115V position for 100/115/120V operation. Set to 230V position for 220/230/240V operation.
2. Plug in the power cable.

On the front panel, set the LINE switch to ON (|).

Power-Up Conditions

At power-up, the Fader returns to the same settings that were present when last turned off.

Preset

PRESET is used to set the Fader to known conditions.

Press the **PRESET/LOCAL** key.

Press **ENTER**.

When a fader has been PRESET, the display will show 70 MHz in the frequency field (140 MHz for option 140), 0 dB in the notch depth field, and 0 dB in the attenuation field.

The PRESET conditions are shown in the following table.

Preset Values

Parameter	Condition
AGC Bandwidth	30 MHz
AGC Frequency	70 MHz (140 in Opt. 140)
AGC ON/OFF	OFF
Alarm Polarity	Positive
ATTENUATION	0.0 dB
DATA POINTS	10
DELAY	6.3 ns
DEVIATION	±1 MHz
DFM TYPE	Bellcore
DISPLAY	ON
ERROR BITS	1024 (2 ¹⁰)
ERROR TERM	ECL/75Ω
FADE EVENTS	OFF
MAX SLEW(RADIO SETUP)	200 dB/sec
MEAS SETUP PHASE	MIN
MK SEARCH	OFF
NOTCH FREQ	70 MHz (140 MHz in Option 140)
NOTCH DEPTH	0 dB

Preset Values (continued)

Parameter	Condition
NOTCH PHASE	MIN
PRINT SELECT	NONE
RADIO BIT RATE	44.7 MHz
RADIO DEMO	OFF
SCALE FACTOR	1
SET START	
Attenuation	0.0 dB
Notch Depth	20.0 dB
Notch Freq	45.0 MHz (115 MHz in Option 140)
Notch Phase	MIN
SET STOP	
Attenuation	0.0 dB
Notch Depth	20.0 dB
Notch Freq	95.0 MHz (165 MHz in Option 140)
Notch Phase	MIN
SIGNATURE TYPE	STATIC
SINGLE SWEEP	OFF
SLEW TIME	100 ms
SLOPES	OFF
SPEED	300 MHz/sec
START RATE	10 MHz/sec
STOP CRITERIA	1E-4
STOP RATE	100 MHz/sec
SYMBOL TIME	50 ns
SWP ALL	OFF
SWP ATTEN	OFF
SWP DEPTH	OFF
SWP FREQ	OFF
SWP TIME	5 seconds
SYNC SOUR	Immediate
TEST MASK	OFF
WAIT TIME	500 mS
ZOOM MODE	OFF
11757A TIMER	RESET

Basic Front Panel Checks

The “Basic Front Panel Checks” provide a method for testing the front panel features of the Fader. This test can be performed at incoming inspection to check Fader operation.

Description

The functions of the Fader are checked using a signal source and a spectrum analyzer. These checks provide reasonable assurance that most of the front panel controlled functions are being executed by the Fader.

Equipment

- Spectrum Analyzer HP 8566B
- Synthesized Sweeper HP 8360 series
- Matching Transformer HP 11694A
- 75Ω Cables HP 8120-3616
- 50Ω Adapters HP 1250-0780

Procedure

1. Turn on the Fader and observe the power up routine. During power up the diagnostics stored in ROM are executed under microprocessor control and turn on all the display segments and annunciators.

The self-test takes about 10 seconds. When the self-test is finished, the Fader will display “SELF TEST OK”.

If an error occurs during the power-up tests, the Fader will display “SELF TEST FAIL”. Try the turn on procedure again. If the FAIL message appears again, refer to the service manual or to your customer representative for information.

2. Press the **PRESET/LOCAL** key, then the **ENTER** key. This sets the Fader Notch Frequency to 70 MHz with a Notch Depth of 0 dB. Start and Stop Sweep

parameters are set to 45 MHz and 95 MHz, but sweep is set to off.

FREQ = 70 MHz
 Start Sweep = 45 MHz
 Stop Sweep = 95 MHz
 DEPTH = 0 dB
 ATTEN = 0 dB

3. Connect the output of the signal generator to the IF Input of the Fader. Use a 75Ω cable, with an adapter at the synthesized sweeper output.

Note



Use Video Trigger on the spectrum analyzer to set a stable trace.

4. Connect the IF Output of the Fader to the input of the spectrum analyzer. Use a 75Ω cable with an adapter at the spectrum analyzer.
5. Set notch depth to 20 dB.

Press **NOTCH DEPTH**
 Press **2 0 ENTER**

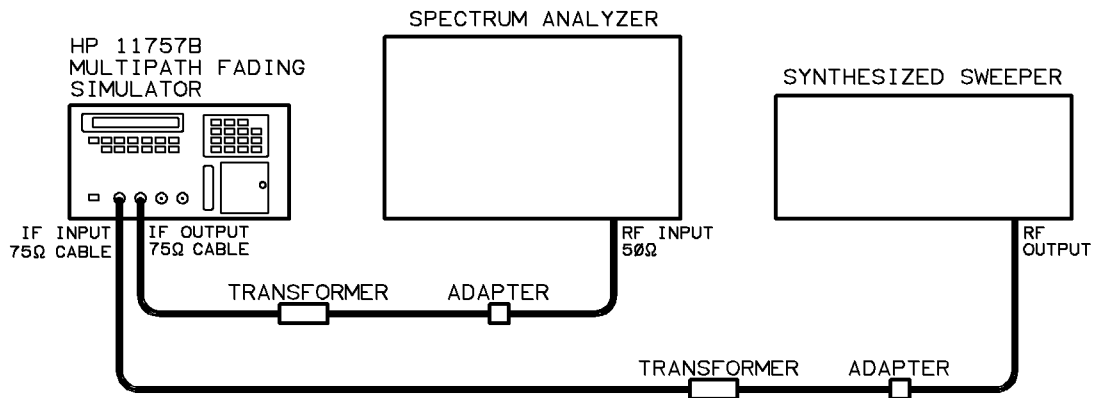

Figure 1-7. Front Panel Checks Setup

6. Set the output of the synthesized sweeper to 70 MHz at a power level of -7 dBm. Set the sweeper for a span of at least ± 25 MHz (you may set a start and stop sweep frequency instead of center frequency and span).
7. Set the range for the spectrum analyzer from 35 MHz to 105 MHz. You should be able to observe a 20 dB notch at 70 MHz.
8. Check the Notch Frequency Sweep function.
 - a. Press **SET START**, then press **NOTCH FREQ**.
 - b. Press **4** **6** **.** **0** and **ENTER**.
 - c. Press **SET STOP**, then press **NOTCH FREQ**.
 - d. Press **9** **4** **.** **0** **ENTER** **SHIFT** **ENTER** (EXIT).
 - e. Press **SHIFT**, then press **NOTCH FREQ** (SWP FREQ).
 - f. The sweep time preset value is 5 seconds. You should be able to view the sweep taking place at this rate.
9. Check the Notch Depth Sweep function.
 - a. Press **SET START** and **NOTCH DEPTH**
 - b. Press **0** **ENTER** **SHIFT** **ENTER** (EXIT)
 - c. Press **SET STOP** and **NOTCH DEPTH**
 - d. Press **3** **0** **.** **0** **ENTER** **SHIFT** **ENTER**
 - e. Press **SHIFT** and **NOTCH DEPTH**
 - f. You will see the Notch Depth and Notch Frequency sweep at the same time. If you wish to see just the Notch Depth sweeping, press **SHIFT** **NOTCH FREQ**. This will turn off the Notch Frequency Sweep.
10. Check attenuation.
 - a. Press **ATTEN**
 - b. Press **2** **0** **.** **0** and **ENTER**
 - c. You will see the flat fade attenuation of 20 dB on the spectrum analyzer.
 - d. To sweep attenuation press **SET START** **ATTEN**

- e. Press **0** **.** **0** **ENTER** **SHIFT** **ENTER**
- f. Press **SET STOP** **ATTEN**
- g. Press **5** **0** **.** **0** and **ENTER** **SHIFT** **ENTER**
- h. Press **SHIFT** and **ATTEN** (SWP ATTEN)
- i. If you wish to turn off the notch depth sweep press **SHIFT** and **NOTCH DEPTH**

Note

For information about other front panel keys and their functions, see the “Detailed Operating Instructions”.

Performance Tests and Adjustments

The procedure that follows verifies that the Multipath Fading Simulator's (Fader) electrical performance meets the specifications described in the HP 11757B User's Guide. It is important that the adjustments are performed in the order indicated to ensure that the instrument meets all of its specifications.

Introduction

The procedures in the performance tests program the Fader's electrical performance to the specifications described in the HP 11757B User's Guide.

These procedures are stored on the HP 11757B Support Disk. These procedures are designed to be used on an HP Series 200/300 controller with BASIC 3.0 or higher. The system must be booted before the procedures can be loaded.

Included with the automated performance tests are automated adjustments. These adjustments can be run if the Fader fails its performance tests. The adjustments will generate new calibration data which is stored in

Installation and Calibration

HP 11757B

battery backed RAM. The data can also be saved to EEPROM using the command **CAL:SAVE**.

Equipment

Network AnalyzerHP 8753B/C at address 716
S-Parameter Test HP 85046A (50Ω)
S-Parameter Test SetHP 85046B (75Ω)
ControllerHP Series 200/300
Inkjet Printer (HP-IB)HP 2225A
75Ω Matching Transformer ..HP 9100-4859 (2 needed)
75Ω BNC Barrel HP 1250-1287

Setup

1. Connect the equipment as shown in figure 1-8.

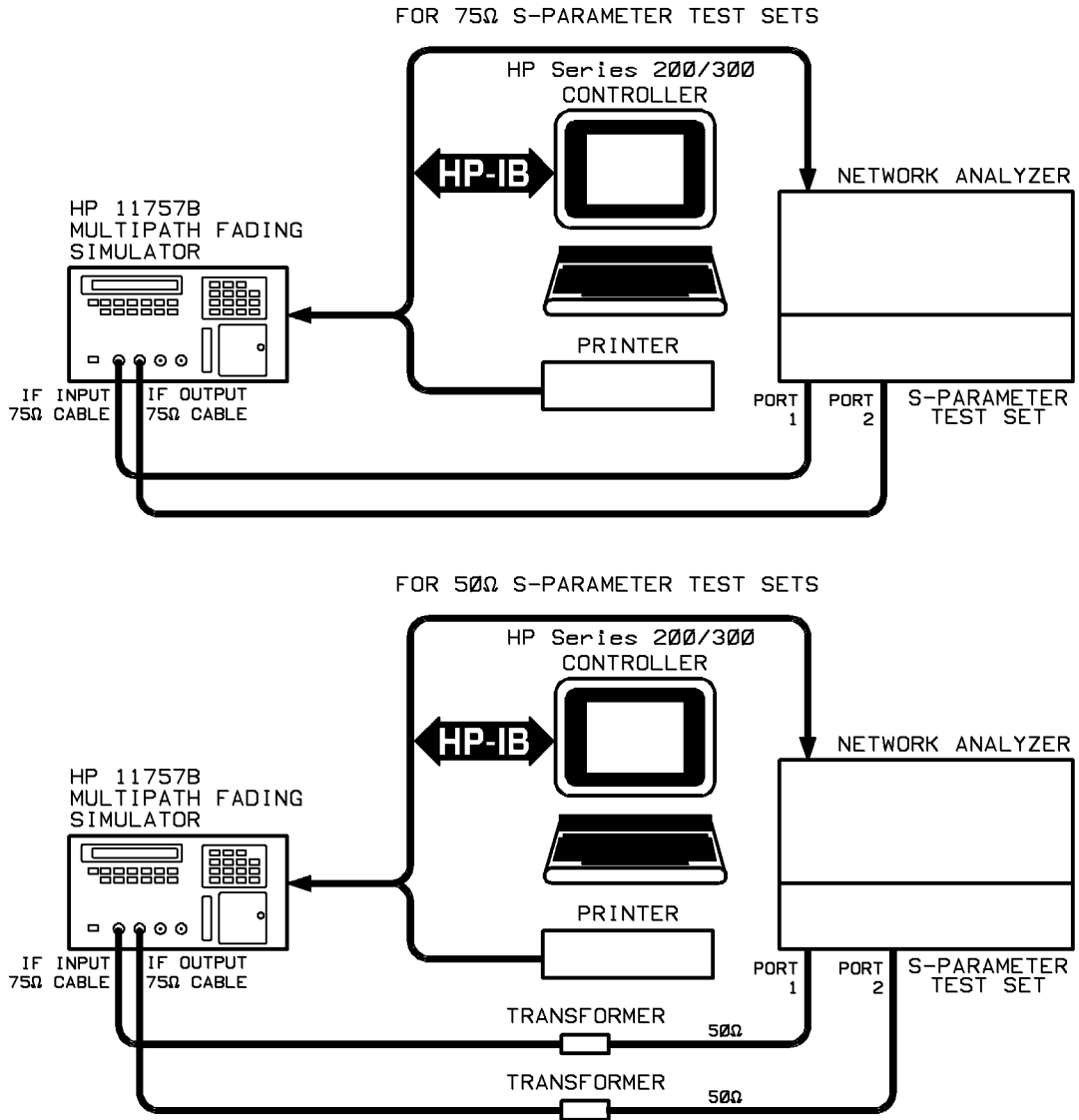

Figure 1-8. Automated Performance Test Setup

2. Insert the HP 11757B Support disk into the controller's disk drive (have BASIC loaded first).

3. Key in LOAD "TEST_11757". Press **ENTER**. Wait for the controller to load the program. The LED on the disk drive will go out when the program has finished loading.
4. When the controller has finished loading the program, press **RUN** or key in RUN to start the program.

Screen #1 allows the user to set the date and time of the test.

The second screen displays information only. Press **ENTER** or **EXECUTE**.

- a. If you want to change the displayed date and time, key in "Y" and press **ENTER** or **EXECUTE**. Follow the displayed instructions.
- b. If you *do not* want to change the displayed date and time, key in "N" and press **ENTER** or **EXECUTE**.

Screen #3 allows the user to enter the MFS's serial number, humidity, temperature, and comments.

Screen #4 is the program selection screen. It lists the actual tests that can be run on the HP 11757B. Do not select any test until you have run the calibration for the Network analyzer/S-Parameter Test Set.

Network Analyzer/S-Parameter Test Set Calibration

Before the adjustments are run, the s-parameter test set must be calibrated.

Note



The s-parameter test set and network analyzer requires one hour of warm-up prior to performing the calibration.

Procedure

1. Connect the equipment as shown in figure 1-9.

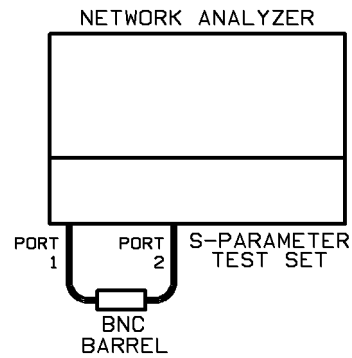

Figure 1-9. S-Parameter Test Set Calibration Setup

2. Press the **CAL** key on the network analyzer.
3. Select the **CAL MENU** softkey.
4. Select **Response**.
5. Select **THRU**.
6. Select **DONE:RESPONSE**.
7. When calibration is finished, reconnect the equipment as shown in Figure 1-8.
8. Follow the directions on the computer display.

Selecting Tests

The main screen of the automated adjustments program is as shown below.

TEST_01: NOTCH FREQUENCY ACCURACY	PERFORMANCE TEST
TEST_02: NOTCH DEPTH ACCURACY	PERFORMANCE TEST
TEST_03: ATTENUATOR ACCURACY	PERFORMANCE TEST
TEST_04: COMPLETE PERFORMANCE TESTS	(01,02,03)
ADJUST 1 ATTENUATION	ADJUSTMENT
ADJUST 2 NOTCH FREQUENCY	ADJUSTMENT
ADJUST 3 NOTCH DEPTH	ADJUSTMENT
ADJUST 4 FLAT FADE	ADJUSTMENT
ADJUST 5 COMPLETE AUTOMATIC ADJUSTMENTS	(1,2,3,4)
STORE ADJUSTMENT DATA IN NON-VOLATILE EEPROM MEMORY	
OPTIONAL COUNTER/EEPROM TEST (FOR 11757B/11758B only)	
SET OPTIONS: WORKS ONLY WITH Firmware REV 9.3 AND UP	
QUICK CHECK FOR DEBUGGING	
DELAY ACCURACY	

Figure 1-10.

TEST_01, TEST_02, and TEST_03 are automated performance tests. ADJUST 1 through ADJUST 5 are automated adjustments, and are covered in chapter 2 of the Service Manual. The STORE ADJUSTMENT DATA function allows the user to store the calibration data (collected in the automated adjustments) in the EEPROM internal to the MFS. The following discussion will focus on the automated adjustment procedures.

The adjustments may be selected either individually or as a group. ADJUST 1 through ADJUST 4 adjust individual parameters of the HP 11757B. ADJUST 5 performs a complete adjustment (ADJUST 1 through ADJUST 4).

Note

TEST_01 through TEST_03 and ADJUST 1 through ADJUST 4 are band dependent. For proper testing, the frequency band must be selected before the test is run. When in the main screen softkey **Select Band** will



allow the user to run the test in either the 70 or 140 MHz frequency band.

Procedure

Note



The Multipath Fading Simulator requires one hour of warm-up prior to performing these tests and adjustments.

1. Using the  or  keys, position the highlight bar over the desired adjustment.
 2. Highlight TEST_04: COMPLETE PERFORMANCE TESTS (01, 02, 03).
 3. Press the **Select Item** softkey. The tests will start to run.
-

Note



This procedure is to be used whenever any kind of repair or alteration is made to the HP 11757B, even if it only involves loosening and re-tightening a cable. Figure 1-11, “Adjustment Procedure Flowchart”, illustrates how the adjustment procedure should be performed.

4. Check the PASS/FAIL STATUS printed at the bottom of each printout page.
-

Note



The Standard model and Option 140 provides 4 printouts plus a summary sheet.

The Option 147 provides 8 printouts plus a summary sheet.

5. Check the PASS/FAIL STATUS printed at the bottom of each page and the summary sheet.
6. If all the statuses are “Passed”, the tests are complete. Press the **Exit** softkey.

7. If any status is “Failed” highlight ADJUST 5 COMPLETE AUTOMATIC ADJUSTMENTS (1, 2, 3, 4) and press **SELECT ITEM**. Leave the equipment set up as shown in figure 1-8..

Note

The automated adjustments may take up to two hours per band to complete. If your Fader is option 147, it may take four hours to complete automated adjustments.

8. When the automated adjustments are finished, highlight TEST_04 COMPLETE PERFORMANCE TESTS (01, 02, 03) and press **SELECT ITEM**.
9. Check the PASS/FAIL STATUS printed at the bottom of each printout page and the summary sheet.
10. If the tests now pass, you may want to store your new calibration data in EEPROM. Highlight STORE ADJUSTMENT DATA IN NON-VOLATILE EEPROM MEMORY and press **SELECT ITEM**.
11. If the Performance Test printout still indicates a failure, refer to chapter 3 of the Service Manual, “Troubleshooting”.

Note

Figure 1-11 shows the sequence of tests necessary after repair of the Multipath Fading Simulator.

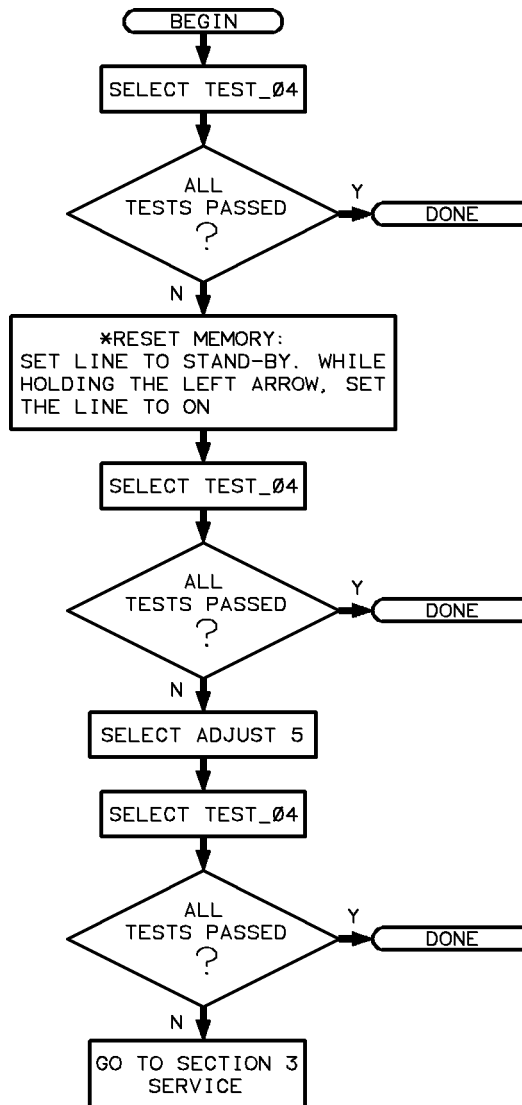

Figure 1-11. Adjustment Procedure Flowchart

34 This Page Intentionally Left Blank